

- 1
- 2
- 3
- 4
- 5
- 6
- 7
- 8
- 9
- 10
- 11
- 12
- 13
- 14
- 15
- RH

FEATURES AND APPLICATIONS

MPI-15 measuring system, made of a LCD multifunction display with built-in magnetic position sensor, combined with the magnetic band M-BAND-10 (to be ordered separately), is a complete system for the measurement of linear and angular displacement (with a minimum radius of 65 mm).

Characterised by an extremely easy assembly, it allows precise alignment and positioning, reducing time and machining procedures to the minimum.

- Multifunction LCD with 5 function keys.
- Absolute / incremental mode.
- Programmable offset function.
- External battery power supply 1.5 VDC.
- Buffered memory during battery substitution.
- Accidental polarity inversion protection.
- Material of the magnetic sensor envelope: anodised aluminium.

For further information read the operating instructions.

ACCESSORIES ON REQUEST

Magnetic band M-BAND-10.

SPECIAL EXECUTIONS ON REQUEST

The display of special plate may be supplied with customised graphic symbols, marks or writings.

Magnetic sensor with cable length different from the standard executions shown in the table, up to 20 m maximum.

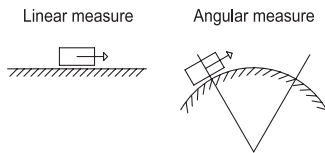

Technical data	
Battery life	1.5 years (C-type battery)
Resolution(1)	0.1 mm - 0.01 in - 0.01°
Precision(2)	0.1 mm
Repeat accuracy(3)	0.001 mm
Operating speed	max. 2.5 m/s
Self-diagnostic	battery check, sensor check, magnetic tape check
Programmable measuring unit	millimetres, inches, degrees (angles)
Working temperature	0 ÷ 50 °C
Storing temperature	-20 ÷ +70 °C
Relative humidity	Max. 95% at 25°C without condensation
Protection class	IP40 whole device IP54 front side according to IEC 529 IP67 magnetic sensor
Interference protection	IEC 61000-4-2

(1) Resolution: the smallest change in length that the system is capable of displaying.

(2) Precision: the maximum deviation of the value measured by the system from the actual one.

(3) Repeat accuracy: the degree of closeness between a series of measures of the same sample, when the single measurements are carried out with the conditions unchanged.

ASSEMBLY INSTRUCTIONS

1. Make a drilling of 42 +0.2/+0.5 mm x 90 +0.2/+0.5 mm in the metal sheet for the installation of the display.
2. Fix the display to the panel by using the specific mounting bracket (the screw is included in the supply).
3. Make a drilling of diameter 34 +0.2/+0.5 mm in the metal sheet for the installation of the battery case.
4. Fix the battery case to the panel by using the specific nut.
5. Fix the magnetic sensor by using M3 screws (not included in the supply). Distance between sensor and magnetic band: max 2.5 mm.

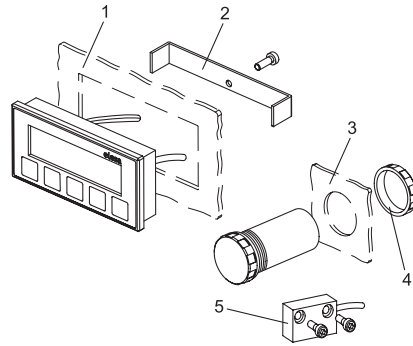

Drilling template for display

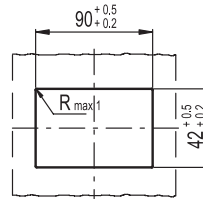

Drilling template for battery case

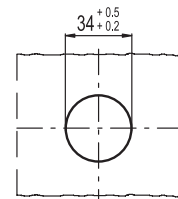

(remove all drilling burrs before fitting the display / battery case)

METRIC

Code	Description	Cable length [mm]	⚖️
CE.99901-02	MPI-15-02	200	228
CE.99901-03	MPI-15-03	300	229
CE.99901-04	MPI-15-04	400	230
CE.99901-05	MPI-15-05	500	232
CE.99901-06	MPI-15-06	600	233
CE.99901-07	MPI-15-07	700	235
CE.99901-08	MPI-15-08	800	236
CE.99901-09	MPI-15-09	900	238
CE.99901-10	MPI-15-10	1000	239
CE.99901-11	MPI-15-11	1100	241
CE.99901-12	MPI-15-12	1200	242
CE.99901-13	MPI-15-13	1300	244
CE.99901-14	MPI-15-14	1400	245
CE.99901-15	MPI-15-15	1500	247
CE.99901-16	MPI-15-16	1600	248
CE.99901-17	MPI-15-17	1700	250
CE.99901-18	MPI-15-18	1800	251
CE.99901-19	MPI-15-19	1900	252
CE.99901-20	MPI-15-20	2000	254

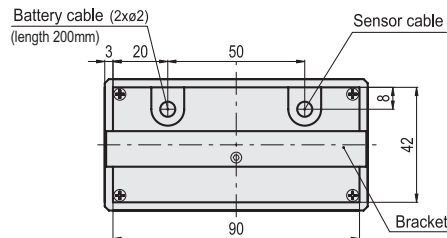
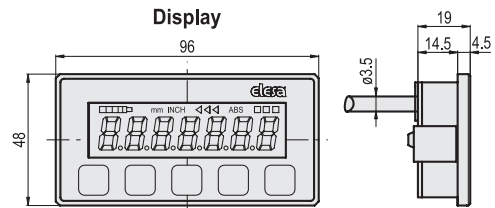

Battery case

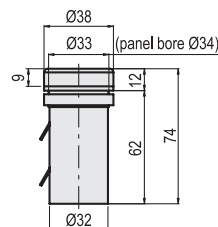

Magnetic sensor

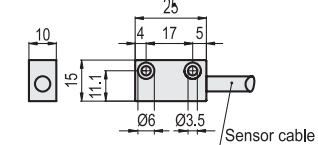

Position indicators

